

FE 40 AIR MAGNETIC DRILLING MACHINE

PERMANENT MAGNET
FOR PIPES AND FLAT MATERIAL

The **FE 40 AIR semi-automatic magnetic drilling machine**, the all-rounder. This machine is supplied with auto coolant system cleverly mounted on top of the machine. This semi-automatic magnetic drilling machine is powered by a strong 1180 watt motor.

Its semi-automatic feature makes it an easy machine to work with. The drilling process is taken care of automatically up to the moment the hole cutter is through the material.

All our machines can be supplied in 110 Volt as well as in 230 Volt

Motor output:	830 Watt
Nominal torque:	27 Nm
Air consumption:	1000 l/min
Stroke:	150 mm
Magnet size:	90 x 190 x 60 mm
Weight:	17.5 kg
Quick charge drill chuck system:	KEYLESS, 19 mm Weldon (3/4")
Morse taper:	MT 2
Speed range 1:	min 290 min-1, max 575 min-1
Permanent internal lubrication:	✓
Core drill short 30 mm:	12 – 35 mm
Core drill long 55 mm:	12 – 35 mm
Twist drilling:	≤ Ø 23 mm

	
max. Ø 35 mm	max. Ø 23 mm

MEASUREMENTS

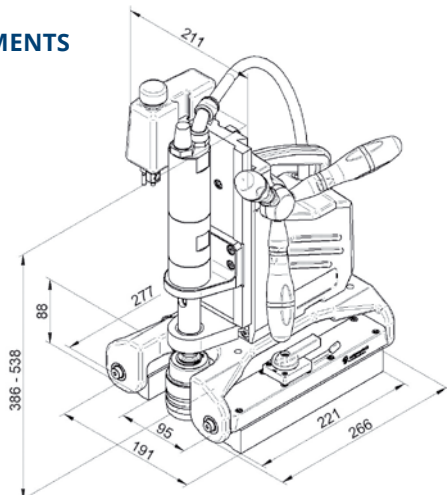

230 V

110 V



STANDARD DELIVERY OF MAGNETIC DRILLING MACHINE FE 40 AIR CONTAINS:

- 1 Magnetic core Drilling Machine
- 1 PP carrying case
- 1 safety chain
- 1 user manual/safety guidelines