

FE RAIL 36 MAGNETIC DRILLING MACHINE

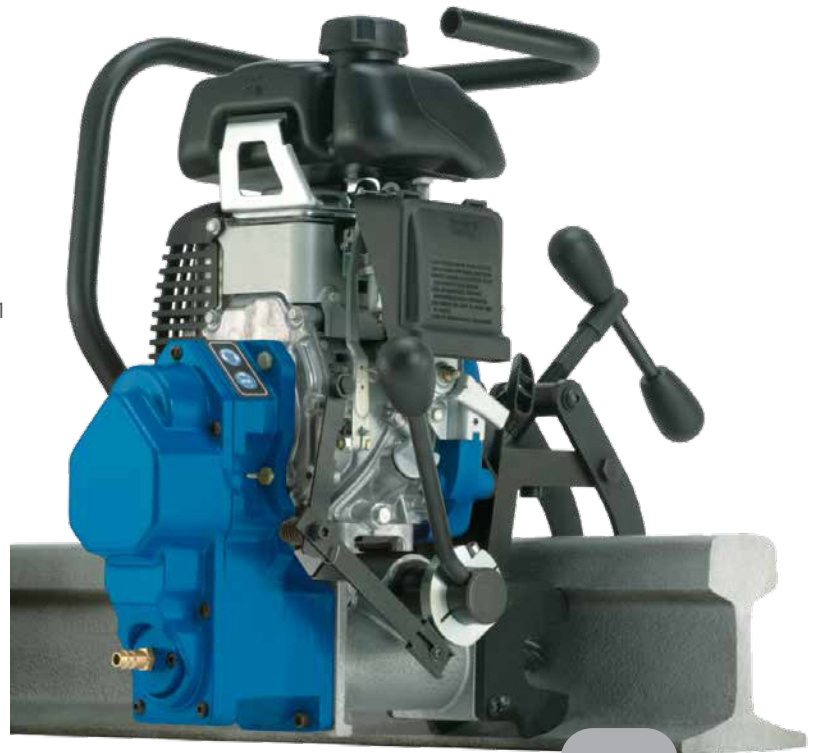

Rail Core Drilling Machine with petrol driven engine
Portable Rail Drills / drilling machine specialized for drilling holes in rails

Motor:	Power 1.5 Kw
Motor:	4 stroke Honda GXH 50 (fuel)
Direct arbor:	19 mm Weldon (3/4")
Stroke	40 mm
Speed range 1:	min. 150 min-1, max. 225 min-1
Permanent internal lubrication:	Yes
Core drill HKK-R:	Ø 17 – 36 mm
Cooling:	With drilling emulsion
Weight:	21.5 Kg



230 V

110 V

max. Ø
35 mm

MEASUREMENTS

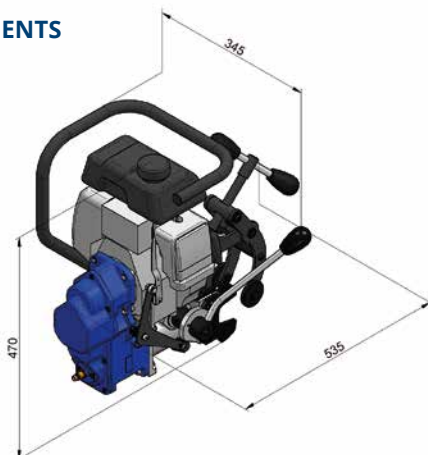

OPTIONAL RAIL ADAPTERS:

UIC 50	S 49
UIC 54	S 54
UIC 60	

STANDARD DELIVERY OF MAGNETIC DRILLING MACHINE FE 36 X CONTAINS:

1 Rail core drilling machine	1 Offset screwdriver
1 High pressure tank, 5 liters	1 Operating manual
1 Rail adapter of your choice (no special version)	